

High-Quality Paving of a Wide Range of Monolithic Profiles

SLIPFORM PAVER SP 33



HIGH-QUALITY PAVING OF A WIDE RANGE OF MONOLITHIC PROFILES



The compact slipform paver can pave a wide range of monolithic concrete profiles such as curbs, curb-gutter profiles, rectangular profiles, concrete safety barriers up to a height of 52 in (1.3 m), drainage channels, and gutter profiles.

In the offset configuration, concrete surfaces up to a paving width of 7 ft (2.2 m) can also be realized in combination with a Trimmer with a width of up to 8 ft (2.44 m) - even slabs with a paving width of up to 10 ft (3.0 m) can be realized in crosspave configuration without a Trimmer.

The slipform paver is ideal for construction sites where a high degree of maneuverability, tight radii and maximum flexibility are required.

Two crawler units with parallelogram swing legs at the front and a laterally adjustable crawler unit at the rear enable zero-clearance paving and maximum flexibility.

The machine can be precisely controlled via stringline scanning, without a stringline using WIRTGEN AutoPilot 2.0, or with third-party 3D applications.



WIRTGEN SLIPFORM PAVERS

OFFSET SLIPFORM PAVERS

- > Offset paving width up to 13 ft (4.0 m)¹⁾
- > Offset paving height up to 10 ft (3.0 m)¹⁾

PLACER / SPREADERS

- > Inset paving width up to 40 ft (12.0 m)¹⁾
- > Inset paving thickness up to 20 in (500 mm)¹⁾

INSET SLIPFORM PAVERS

- > Inset paving width up to 40 ft (16.0 m)¹⁾
- > Inset paving thickness up to 18 in (450 mm)¹⁾

TEXTURE CURING MACHINES

- > Working width up to 59 ft (18.0 m)
- > Working height up to 20 in (500 mm)

AUTOPILOT 2.0 3D CONTROL SYSTEM

¹⁾ Special paving widths, paving thicknesses, paving heights, and other options available on request

OUTSTANDING VERSATILITY

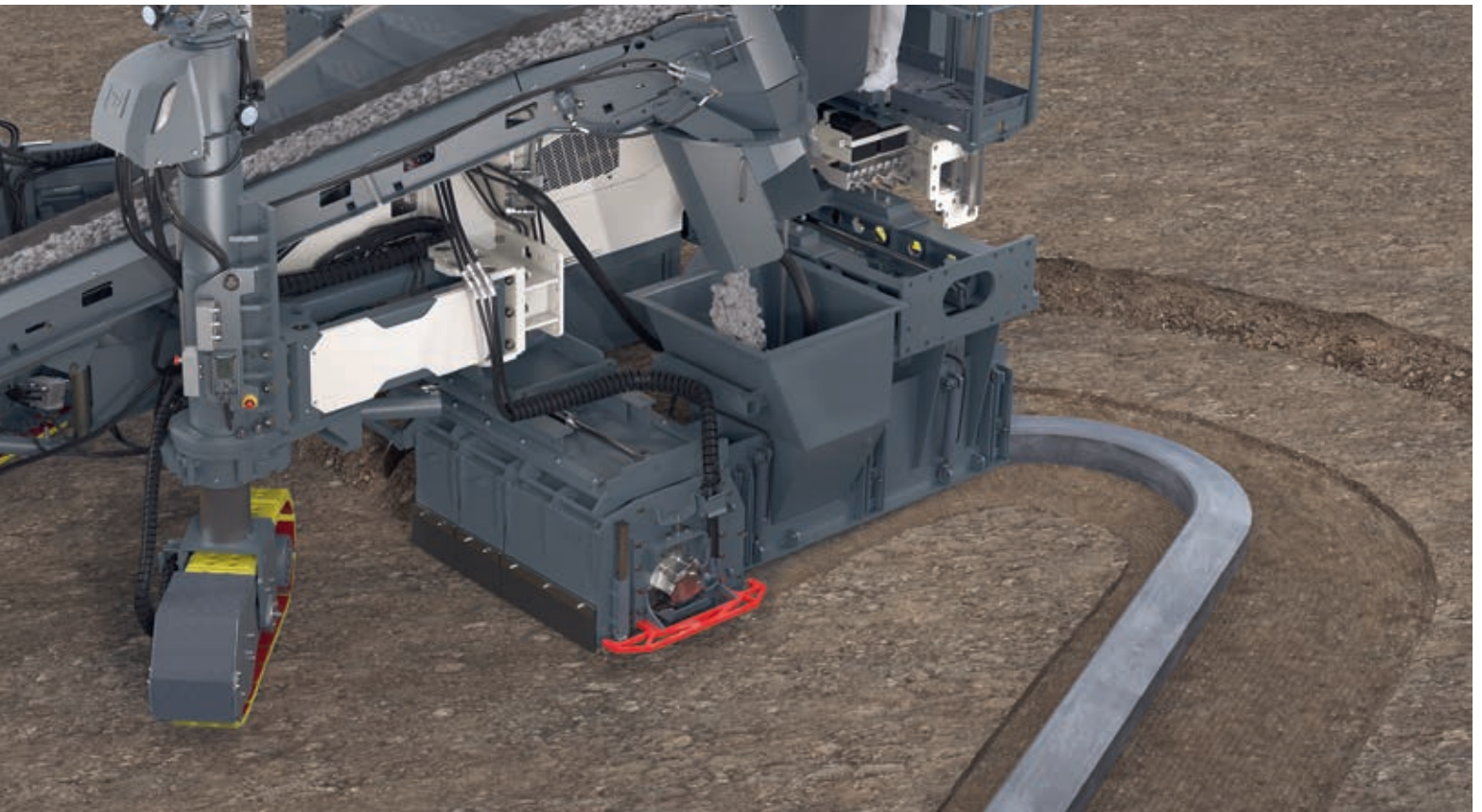

Curb profile with 20 in (0.5 m) inner paving radius, paving left with the offset method, with Trimmer



Embedded V-profile drainage channel, paving left



Special profile with combined paving mold, paving right

Versatile Concrete Paving Thanks to Longitudinal and Crosspave Options

In offset paving configuration, the SP 33 can pave a wide range of different monolithic concrete profiles with or without a Trimmer - e.g. concrete safety barriers up to a height of 52 in (1.30 m) and concrete slabs with a width of up to 7 ft (2.20 m). It can also pave gutters, curb-gutter systems, U-profile drainage channels, foundations, etc.

The ability to shift the moldboard suspension to the right and left and the freely positionable crawler units further increase the spectrum of possible applications. In crosspave- configuration without a Trimmer, the compact all-rounder can also pave subordinate concrete slabs with a paving width of up to 10 ft (3.0 m). These include cycleways, heavy vehicle parking spaces on truck parking areas, and construction objects in rural road construction.



Concrete safety barrier, paving right



Free-standing U-profile channel, paving right



Slot drain, paving right

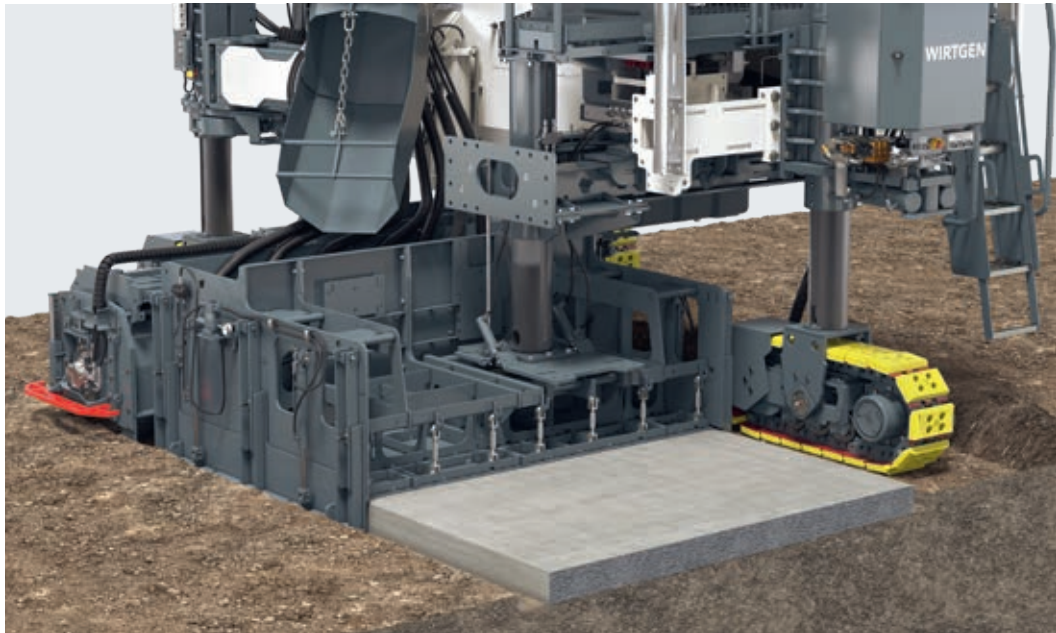

7 ft (2.20 m) walkway profile, paving left in offset configuration, with 8 ft (2.44 m) wide Trimmer



10 ft (3.0 m) cycleway profile, paved in crosspave configuration

OUTSTANDING VERSATILITY

01

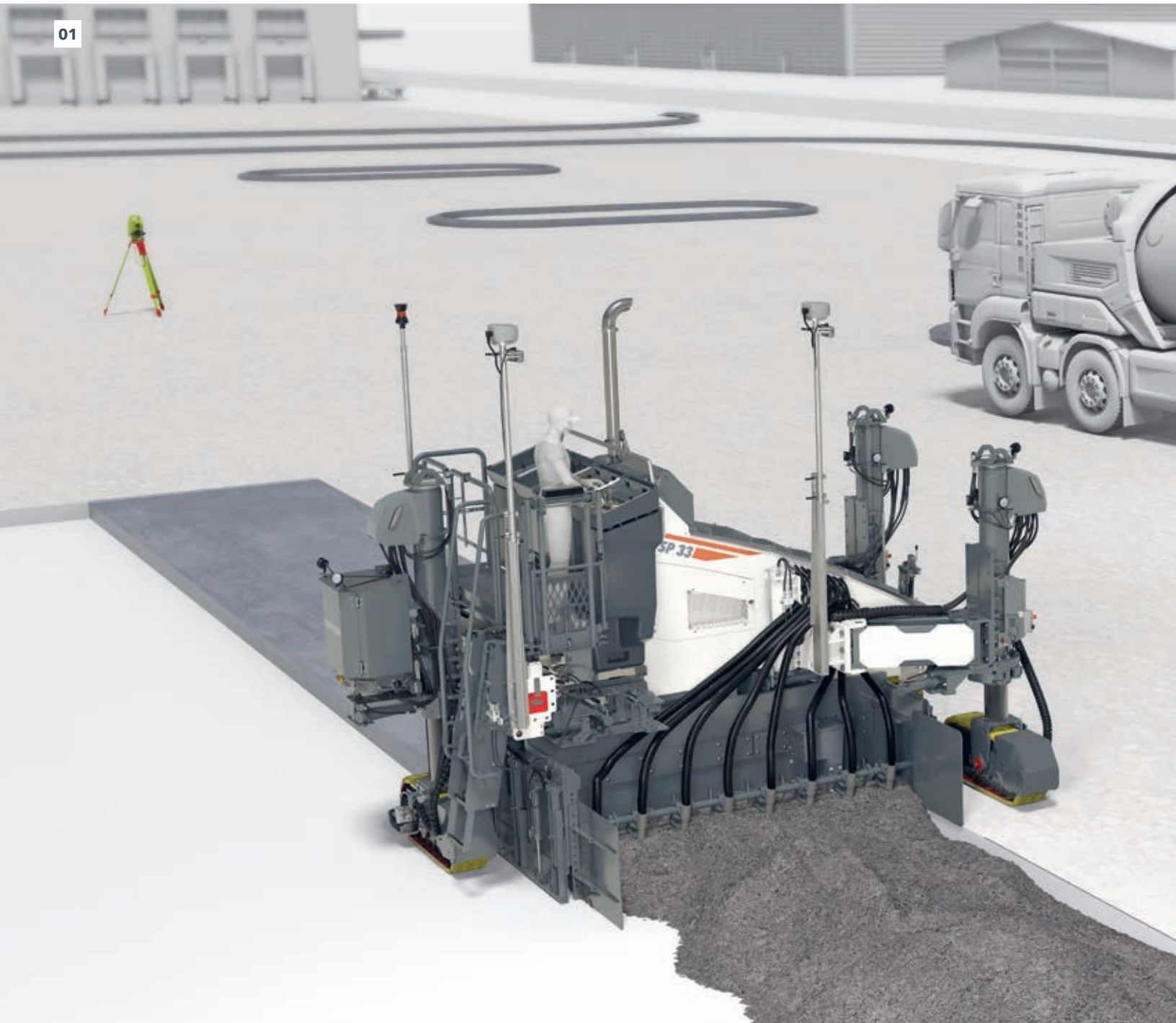

Offset and Crosspave with the Same Machine

Projects often require concrete paving with both offset and crosspave methods. In most cases, this requires the deployment of two differently conceptualized machines. The SP 33, however, perfectly fulfills both of these challenges in one.

The most significant cost factor is that only one slipform paver is required on the construction site - with a simul-

taneously high machine utilization rate. Thanks to the quick-change concept, the changeover from offset to crosspave molds can be carried out quickly and easily on the construction site.

At the same time, the machine can be precisely controlled via stringline scanning, without a stringline using WIRTGEN AutoPilot 2.0, or via third-party 3D applications.

01 The SP 33 reliably carries out the paving of a curb-gutter profile with the offset method and a heavy vehicle parking space in crosspave configuration within the same project.



OVERVIEW OF HIGHLIGHTS

Perfectly Equipped

01 Intuitive Human-Machine interface (MMI)

- > Interactive display of current machine parameters
- > Intuitive operating concept
- > Rugged 8" color touchscreen display
- > Alternative operating option with pushbuttons / rotary switches
- > Increased operational reliability through hardware / software redundancy
- > Vibrator adjustment integrated in the HMI
- > Programmable machine information and favorites buttons
- > Guided operating for transportation, set-up, and concrete paving
- > Easily adjustable speed control function

02 Outstanding Operating Comfort and Smart All-Round Visibility Concept

- > Spacious, raised operator's platform for an ideal overview and freedom of movement
- > Convenient lateral extension of the operator's platform
- > Generously dimensioned stowage compartments
- > Main control panel positionable at the right or left
- > Quick and easy lockable vandalism protection
- > 2" control panel for ground crew for setting up various machine functions



03 Perfection in Environmental Protection, Safety, and Serviceability

- > ECO-Mode diesel engine control for minimization of fuel consumption and CO₂ and noise emissions
- > Easily accessible service and maintenance points
- > Vibration-protected operator's platform and sound-proofed engine compartment
- > Comprehensive premium lighting concept
- > Welcome and Go Home light
- > Integrated flashing lights

04 Maximum Flexibility on the Construction Site

- > Choice of either belt conveyor or auger conveyor
- > New slider bed belt conveyor for low wear operation, a better overview, and easy cleaning
- > Freely-positionable crawler units
- > Optional premium mold suspension with hydraulic clamping and extended telescoping capability
- > Height-adjustable offset mold suspension
- > Hydraulically operated quick-change system for offset- and crosspave molds

05 Increased Versatility Thanks to Crosspave Capability

- > 90° rotatable crawler units for paving concrete slabs up to 10 ft (3.0 m) wide in crosspave configuration
- > Easy machine transportation
- > Minimal reconfiguration effort for switching between offset and crosspave applications
- > Crosspave mold can also be used for offset-paving applications
- > Optionally up to eight hydraulic vibrators

06 Precise and Efficient Leveling and Steering

- > Latest-generation valve technology
- > Fast, precise, and rugged cylinder steering for a variety of steering modes
- > Finely controlled track steering in crosspave configuration
- > AutoPilot 2.0 machine control system - developed by Wirtgen
- > Integrated standard 3D interface

07 High-Performance Trimmer

- > Optional Trimmer for ground preparation to a trimming width of up to 8 ft (2.44 m)
- > Improved geometry enables exceptionally high material flow rate
- > Wide range of adjustment options and easy reconfiguration
- > Continuous trimmer drum speed adjustment
- > Wear-resistant flat picks for long service life and improved material flow



INTUITIVE HUMAN-MACHINE INTERFACE (HMI)

At a Glance

8" color touchscreen display with interactively visualized machine

Everything Under Control

Ergonomic controls

01



Interactive Display of Current Machine Parameters

The SP 33 provides an interactive visualization of the entire machine: The display panel in the direct line of sight of the operator provides a clear, graphic visualization of the movements of all individual components in real-time. Thanks to the comprehensive information this provides, the operator is kept constantly aware of the positioning of the Trimmer and mold and the alignment of the swing legs and crawler units, etc. This in turn guarantees fast diagnostic capabilities. Thanks to the innovative HMI interface, inexperienced operators in particular are quickly familiarized with the machine and can take complete control of machine operation and the entire paving process very soon.

Intuitive Operating Concept

The state-of-the-art operating concept of the SP 33 is precisely tailored to the concrete paving process. It is more intuitive and offers even better ergonomics and comfort for the operator. Easy comprehension is assured by the language-independent, symbol-based visualization of the machine functions. The operator can immediately identify which components are active and which machine functions can be carried out. In addition, all functions can be implemented with just one hand. The improved ergonomics and haptics of important control elements - for instance the proportional height adjustment joystick - make everyday work with the machine even easier.

Ruggedized 8" Color Touchscreen Display

The high-resolution 8" multi-touch-display is characterized by ruggedized, cutting-edge design. The good legibility and operability of the color display even in strong sunlight and rain, ensure fatigue- and stress-free working. In addition, the display panel also features dazzle-free back-lighting for greater efficiency when working at night. A further benefit is the ability to use the control panel when wearing gloves. More than ten different languages are currently available.

Alternative Operating Option with Pushbuttons / Rotary Switches

As an alternative to touchscreen operation, the operator can also easily control the machine with a range of intuitively positioned pushbuttons and rotary switches.

Increased Operational Reliability Through Hardware / Software Redundancy

The modular construction of the rugged and reliable CAN bus network enables easier machine diagnostics and rapid exchange of components in the event of failures. The main controls feature dual-channel signal transmission to ensure that functions are still executed even if one signal fails. Information about a signal failure is also displayed to the operator.



01 The intuitive, HMI-based operating concept of the SP 33 significantly increases operator efficiency.

02 Electric proportional joysticks enable fine control of machine settings with outstanding precision.

INTUITIVE HUMAN-MACHINE INTERFACE (HMI)

State-of-the-Art Operating Concept

Familiar with the Machine in No Time

Vibrator Adjustment Integrated in the HMI

Optimum Concrete Consolidation

01



Vibrator Adjustment Integrated in the HMI

Thanks to the intuitive one-hand operating concept of the SP 33, the operator can easily adjust the speed of the electric or hydraulic vibrator from the main control panel. The corresponding vibrator speed setting is simultaneously shown in graphic form on the display.

Hydraulically controlled proportional valves for the hydraulic vibrators are also installed on the machine. These make it possible to quite easily set the speed for all vibrators separately or for individually defined vibrator groups from the main control panel. For example, in the case of offset profiles with complex geometries such as concrete safety barriers, the vibrators have to process the concrete with varying degrees of intensity to ensure consistent consolidation in the individual zones. The speed of all grouped vibrators can be easily adapted to the respective concrete properties at the same time, even during the ongoing paving process.

Freely Programmable Machine Information and Favorites Buttons

Eight favorites buttons arrayed on the main control panel can be programmed with preferred machine functions - this also increases the operational reliability of the SP 33. In addition, the operator can display freely-configured machine information and important paving parameters on the display's machine data bar.

Guided Operating for Transportation, Set-Up and Concrete Paving

The display features separate zones for the clear and simple presentation of relevant machine information for each of the three main working phases: Transport, Set-Up, and Concrete Paving.

For instance, the Set-Up zone visualizes the set-up process in a logical sequence that avoids errors by walking the operator through the successive set-up of individual systems such as the crawler units, the mold, the vibrators, the sensors, etc. This ultimately leads to an intuitive, significantly more efficient set-up process that even inexperienced personnel can learn quickly.

Easily Adjustable Speed Control Function

The SP 33 is equipped with a speed control function: This enables the operator to simply set the machine advance rate or paving speed dependent on the actual availability and consistency of the concrete and save the settings for subsequent projects. This also assures consistently high concrete paving quality.



01 The intuitive operating concept provides clear and easily comprehensible information.

02 The speed of individual vibrators or groups of vibrators ...

03 ... or the cross slope can be conveniently set from the main control panel.

OUTSTANDING OPERATING COMFORT AND SMART ALL-ROUND VISIBILITY CONCEPT

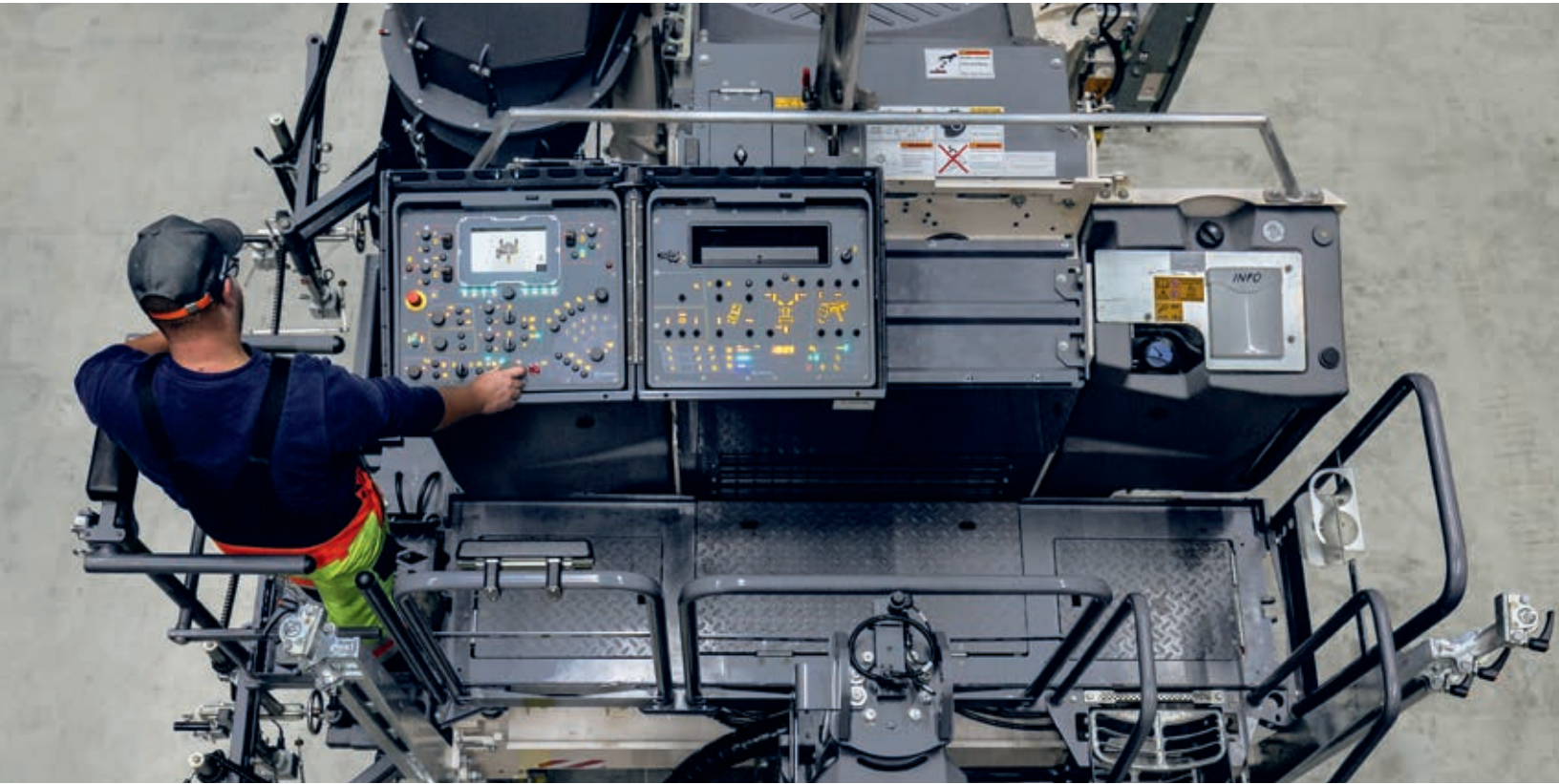

Spacious, Raised Operator's Platform for an Ideal Overview and Freedom of Movement

The ergonomically designed operator's platform offers ample space and freedom of movement and affords machine operators the best possible overview of all important working areas - e.g. the concrete feeding process. Two factors that play a particular role in this are the raised operator's platform and the improved freedom of movement it offers.

Convenient Lateral Extension of the Operator's Platform

On top of this, retractable extension elements at the right and left widen the platform by up to 14 in (350 mm) to allow for an excellent overview of the ongoing paving process. This can be carried out conveniently from the operator's platform with significantly reduced physical effort.

Generously Dimensioned Storage Compartments

The machine offers ample storage space for tools, lamps, and ancillary parts such as sensors, etc. More storage space is provided by the extra-large toolbox on the rear of the machine as a standard fitting and an optionally available compartment for the main control panel.

Main Control Panel Positionable at the Right or Left

Depending on the task at hand, the main control panels of the SP 33 can be positioned at various points on either side of the machine and thus constantly provide an ideal overview of the paving process, the machine, and the surrounding area. The 8" color touchscreen display on the control panel provides event-driven information about all relevant operational data.



01

Quickly and Securely Attachable Covers and Lockable Control Panels

The innovative, integrated vandalism protection system reliably protects the control panels against vandalism or theft. In addition, the control panels on both sides can be quickly folded up and locked before cleaning the machine. The vandalism protection elements are securely bolted to the machine to ensure that no loose covers interfere with the work at hand.

2" Control Panel for Ground Crew for Setting Up Various Machine Functions

Optionally, up to five 2" control panels can be installed on the three lifting columns and next to the mold on both sides.

The individually programmable favorites buttons on the panels can be easily accessed and used by the ground crew. Each panel can be programmed with a wide range of custom functions such as steering and slewing the crawler units and swing legs, resetting to zero control position, machine height adjustment, etc.



02



03



04



05

01 Quick and secure locking of the control panel.

02 The control panel can be positioned on the right or left for optimum visibility.

03 2" control panels allow the ground crew to directly select individually preferred functions.

04 Ample storage space is provided.

05 The operator's platform can be extended laterally with minimal effort.

PERFECTION IN ENVIRONMENTAL PROTECTION, SAFETY, AND SERVICEABILITY

ECO-Mode diesel engine control to minimize diesel fuel consumption and CO₂ and noise emissions

The automatic determination of power requirements ensures that the diesel engine runs within the envelope of optimal efficiency. This enables low diesel fuel consumption and simultaneously reduces CO₂ and noise emissions. The load-dependent ECO mode diesel engine control system identifies every working situation without the need for manual intervention by the operator.

Easily Accessible Service and Maintenance Points

The three-part engine cover with three identical panels can be removed separately with minimal effort for access to specific service points. The low net weight of the individual covers allows them to be handled easily by just one person. Furthermore, uncomplicated access to all other service and inspection points reduces maintenance effort to a minimum - typical examples of this are the wide-opening, magnetically-lockable doors of the electrical cabinets on the operator's platform.



Easy Maintenance

Easily accessible maintenance points

Built-in Sustainability

Fuel-Saving, Low-Emission ECO Mode



Vibration-Protected Operator’s Platform and Soundproofed Engine Compartment

Effective engine soundproofing, elastic engine mounts, and anti-vibration-mounted treads guarantee low noise emissions, which in turn ensures a fatigue- and stress-free working environment.

Comprehensive Premium Lighting Concept

In the standard version, the SP 33 is equipped with one freely positionable and three fixed high-performance LED working lights. The premium concept for particularly flexible lighting of the entire machine, the paving process, and the area around the machine offers eleven LED working lights, of which eight are in fixed positions and three are freely positionable. Also available is an optional, dimmable high-performance 24V floodlight for illumination of the entire construction site.

“WELCOME AND GO HOME LIGHT”

At the push of a button, the access ladder and the operator’s platform can be conveniently illuminated when approaching and walking away from the machine.

Integrated Flashing Lights

Clearly visible at long distances, the extremely bright flashing lights on all three lifting columns ensure additional safety and visibility on the construction site, especially when working in the dark.

- 01** Easily removable, lightweight engine covers allow quick and easy access to the engine compartment.
- 02** The ECO-Mode diesel engine control system can be manually activated.
- 03** All service points are also conveniently accessible from the ground.
- 04** High-performance LED working lights guarantee ideal illumination of the construction site at all hours.

MAXIMUM FLEXIBILITY ON THE CONSTRUCTION SITE

Choice of Either Belt Conveyor or Auger Conveyor

Customers can order an SP 33 with either a belt conveyor or an auger conveyor. Both options can be flexibly adjusted hydraulically via a multi-axis suspension system. Factors in favor of a belt conveyor are its high concrete conveying speed and easy accessibility. Compared to the belt conveyor, the auger conveyor can be adjusted to a considerably steeper angle of up to 45°. In addition, the auger conveyor can hold larger quantities of concrete as a buffer.

New Slider Bed Belt Conveyor for Low Wear Operation, a Better Overview, and Easy Cleaning

The newly developed, particularly flat slider bed belt conveyor has been designed especially for concrete paving applications with slip-form pavers. In combination with its lower attachment point on the machine, the considerably reduced constructional height of the slider bed belt conveyor allows for an ideal overview of the concrete feeding process. As it works with relatively few moving wearing parts, it needs very little maintenance, offers easy access to the belt, and optimal sealing - all of which considerably reduce the effort required for cleaning.

01



Exceptional Versatility

Variable Suspension of the Paving Mold

Quick and Easy Maneuvering

Freely-Positionable Crawler Units

Freely-Positionable Crawler Units

The two front crawler units of the SP 33 are designed to be swung out hydraulically for maximum adaptability to the situation on construction sites. The rear crawler unit can be mechanically or hydraulically shifted to ideally adapt the positioning of the mold to the conditions on the construction site. Lastly, the maneuverability of the machine is increased by the innovative 90° cylinder steering of all three crawler units - e.g., for simple lateral movement out of a paving operation, maneuvering into position, and now, for the first time, for crosspave applications.

Optional Premium Mold Suspension with Hydraulic Clamping and Extended Telescoping Capability

The mold can be mounted to either the right or left side of the machine to ensure that the different requirements of construction sites can always be met. Hydraulically telescoping mold suspension additionally enables lateral shifting of the mold - for paving profiles inside or outside the machine dimensions. The maximum telescoping in two steps amounts to a distance of up to 48 in (1,200 mm). Hydraulic clamping for securing the mold can be conveniently activated from the operator's platform.

Height-Adjustable Offset Mold Suspension

The hydraulically height-adjustable suspension for offset molds offers an increased lift of 20 in (500 mm).

Hydraulically Operated Quick-Change System for Offset- and Crosspave Molds

The hydraulically operated quick-change system saves time and minimizes the effort required when exchanging the various offset- or crosspave molds. A simple process: just lower the machine, drive it forward, and lock in the mold - that's all.

01 The maintenance-friendly, flat slider bed belt conveyor provides a better overview of the concrete feeding process.

02 Ideal maneuverability for paving operations on construction sites with restricted space.

03 Height-adjustable and telescoping mold suspension including quick-change system for molds.



INCREASED VERSATILITY THANKS TO CROSSPAVE CAPABILITY

90° Rotatable Crawler Units for Paving Concrete Slabs up to 10 ft (3.0 m) Wide in Crosspave Configuration

Thanks to the three 90°-rotatable crawler units, the SP 33 can maneuver in the transverse direction and realize crosspave applications. Efficient track steering provides outstanding maneuverability and steering capabilities. At the same time, the effort required for switching between offset- and crosspave applications is minimal.

Broader spectrum of applications: In crosspave configuration, the slipform paver is able to pave concrete slabs with paving widths of up to 10 ft (3.0 m), for example, footpaths, cycleways, agricultural roads, heavy vehicle parking strips, etc. In addition to this, the attractively priced, weight-optimized mold ensures particularly high overall efficiency.

Easy Machine Transportation

The SP 33's outstanding maneuverability and compact dimensions allow quick and easy loading and transportation. Crosspave molds with a working width of up to 10 ft (3.0 m) do not need to be removed, but can remain on the machine during transport. Offset molds with a narrow profile width can also remain on the machine.

Minimal Reconfiguration Effort for Switching Between Offset- and Crosspave Applications

Thanks to the quick-change concept, the switch from offset- to cross-paving molds is particularly quick and easy. For instance, an offset mold including the associated hydraulic quick-connectors can be removed from the machine and set aside with very little effort, and



- 01** The switch from an offset mold to a crosspave mold can be carried out in no time at all.
- 02** Convenient - connector blocks for up to eight hydraulic vibrators at the left and right.
- 03** In crosspave configuration, the SP 33 can pave paths and roadways with a width of up to 10 ft (3.0 m).



a crosspave mold can be mounted in its place just as quickly by only one person. Many other components, such as the offset mold suspension or the water tank mounted on the underside of the paver can also remain on the machine.

The Crosspave Mold Can Also Be Used for Offset-Paving Applications

The universal suspension system is identical for both offset- and crosspave molds. This means that crosspave molds with working widths of up to 7 ft (2.2 m) can also be used for offset-paving applications.

Optionally up to Eight Hydraulic Vibrators

The SP 33 can be equipped with up to eight high-performance hydraulic vibrators with frequencies that can be individually set as required from the operator’s platform. Eight vibrators are required for crosspave applications with a working width of up to 10 ft (3.0 m). Connections for the corresponding vibrators are provided at the left and right and are easily accessible from the ground.

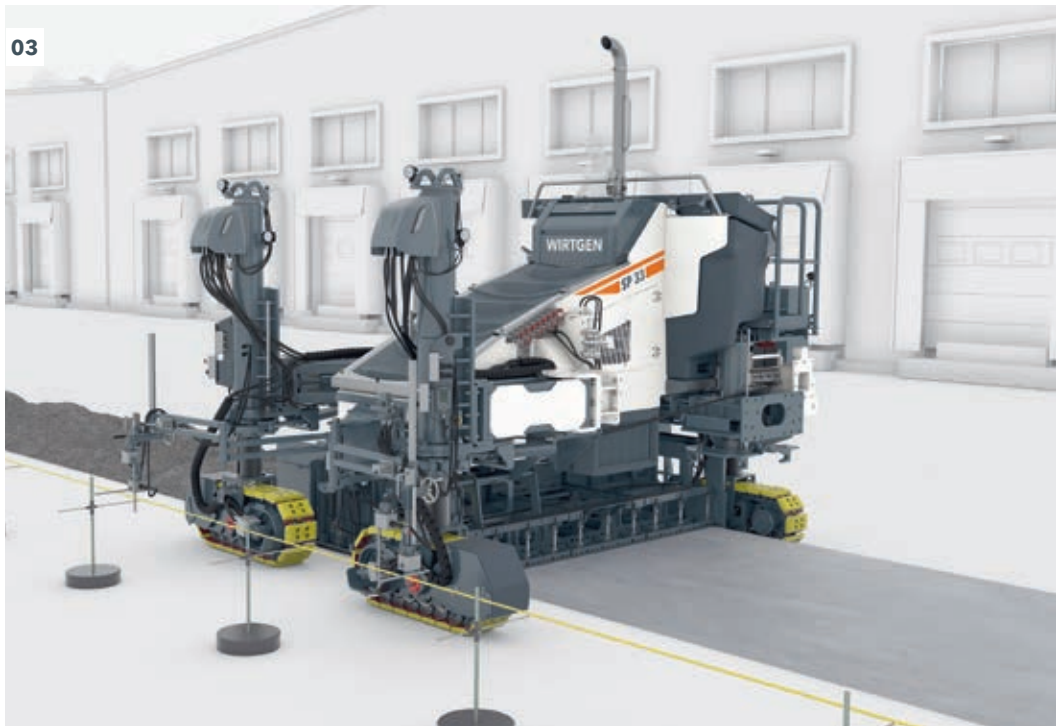

Longitudinal and Cross Concrete Paving
Wide Range of Paving Applications

PRECISE AND EFFICIENT LEVELING AND STEERING

Latest-Generation Valve Technology

High quality, extremely precise valves with CAN-bus technology are installed in the SP 33 for the advance drive, steering, and machine leveling. These allow copying of existing references with exceptional tracking accuracy, extremely smooth operation, and only minimal paving tolerances – especially in tight curves – for the realization of very precise, high-quality concrete paving results.

Ackermann Steering

The field-proven Ackermann steering system guarantees precise machine handling characteristics and optimal concrete paving quality, even under difficult conditions on the construction site.

Fast, Precise, and Rugged Cylinder Steering for a Variety of Steering Modes

The rugged cylinder steering used in the SP 33 allows fast and precise rotation of all three crawler units by 90° – e.g., for switching from offset- to crosspave applications. The cylinder steering reliably supports all available steering modes, such as all-track steering, cornering, diagonal steering, turning on the spot, etc.

Finely Controlled Track Steering in Crosspave Configuration

In crosspave configuration, the track steering employed for cross-paving applications guarantees excellent straight-line travel, precise handling, and optimal paving quality in curves.

01



A Clear Head Start

No Need for a Physical Stringline

Takes Every Corner in Its Stride

High quality, even when paving tight curves

02



01 Maximum precision when paving tight curves.

02 AutoPilot 2.0: The FieldRover reads in the object points of the virtual stringline from which the software calculates the ideal course.

03 The optimized cylinder steering with a two-cylinder concept at the rear to achieve a 90° steering angle also enables crosspave applications.

03



Developed by Wirtgen - AutoPilot 2.0 Machine Control

For maximum concrete paving precision, the machine can be controlled without a physical stringline with the AutoPilot 2.0 system, developed by WIRTGEN. In addition, the software enables the generation of new, digital 3D data models on the construction site. The advantages: It eliminates the need for surveying, setting up, and dismantling of stringlines, and wires no longer hinder the crew working around the paver or the delivery of concrete to the machine. In turn, this increases on-site safety as well as the productivity and cost-efficiency of the entire paving process chain.

Integrated Standard 3D Interface

Thanks to an integrated, field-proven standard interface, the SP 33 provides the ideal prerequisites for concrete paving with predetermined digital terrain models. Strict approval procedures assess and confirm compatibility with 3D control systems from leading suppliers and assure high levels of operational reliability.

HIGH-PERFORMANCE TRIMMER

Perfectly Even Ground

Uniform Profile Paving on Every Project

100% Higher Material Flow

Improved Trimmer Housing and Trimmer Drum

Optional Trimmer for Ground Preparation to a Trimming Width of up to 8 ft (2.44 m)

The powerful helical Trimmer fitted with flat- or round-shank picks smooths insufficiently even ground and guarantees uniform paving of concrete profiles. The height and lateral inclination of the Trimmer, which is positioned directly in front of the offset slipform mold, are adjustable, and it can also be telescoped laterally. Starting from the basic width of 61 cm, the unit can even be gradually widened up to a maximum of 8 ft (2.44 m) for paving concrete profiles with a width of up to 7 ft (2.2 m).

Improved Geometry Enables Exceptionally High Material Flow Rate

The significantly larger cutting circle and the greater overall size of the trimmer housing provide more room not only for the material removed by trimming but also for larger rocks, resulting in a 100% increase in the material flow achieved by its predecessor. The combination of ideal pick arrangement on the trimmer drum and the optimized shape of the wear-resistant outer housing guarantees maximum performance and the smoothest possible running in every usage scenario. At the same time, a range of setting options enables optimum material discharge, including for larger volumes of milled material.

01



Wide Range of Adjustment Options and Easy Reconfiguration

The height, cross slope, and lateral telescoping of the trimmer can be easily adjusted hydraulically according to performance requirements and conditions on the construction site.

The required working width of the trimmer can be realized efficiently by attaching or removing separate extension elements. A rotatable shaft flange enables the connection of a further discharge auger, making it ideal for use under the tightest construction site geometries. One person can attach or remove the entire trimmer unit in no time at all.

Stepless Trimmer Drum Speed Regulation

Stepless regulation of the trimmer speed to the most efficient setting can be carried out easily from the main control panel on the operator's platform.

Wear-Resistant Flat Picks for Long Service Life and Improved Material Flow

Based on WIRTGEN's unique milling competence, the newly developed flat picks and trimmer drum are precisely tailored to meet the requirements of a Trimmer for a slipform paver. A precisely defined arrangement of the heavy-duty flat picks guarantees optimal surface quality. Another major advantage is the long service life due to minimal pick wear.

01 The up to 8 ft (2.44 m) wide Trimmer offers highest performance ...

02 ... and simultaneously the smoothest possible running.

05 The rotatable shaft flange enables the connection of a further discharge auger.

03 Stepless trimmer drum speed regulation on the main control panel.

04 The heavy-duty flat picks ensure a long service life and improved material flow.



WIDE RANGE OF OPTIONAL EQUIPMENT

Useful Options (can be installed on the standard machine according to customer's wishes)

01 Second Steering Cylinder at the Rear for 90° Steering Angle and Crosspave

Second steering cylinder at the rear to achieve a 90° steering angle. For crosspave applications, additional steering modes, and maneuverability. Front crawler units with default steering lock angle 90°.



02 8 hydraulic vibrator circuits (instead of 6)

Hydraulic vibrator drive for up to eight vibrators. Connection positions available on both sides of the chassis. Six vibrators usable with simultaneous trimmer operation.



03 Crosspave Mold

Mold for crosspave applications without crown, basic width 7 ft (or 2.25 m), for concrete thicknesses of up to 8 in (200 mm). Optional extenders enable working widths of up to 10 ft (3.0 m). Offset paving applications are also possible with optional add-on parts.



04 Premium Mold Board Suspension

Offset mold board suspension left or right with hydraulic clamping. Hydraulically shiftable in two steps by 28 in (700 mm) and 48 in (1,200 mm). Mounting of slab molds possible in crosspave configuration.



05 2" Control Panel

Additional 2" control panel that can be freely programmed with up to eight preferred functions per control panel. Up to five additional control panels can be mounted on the track units and centrally on the chassis. With helix cable.



06 Quick-Change System for Offset- and Crosspave Molds

Hydraulically operated quick-change system for faster reconfiguration with different offset- or crosspave molds.

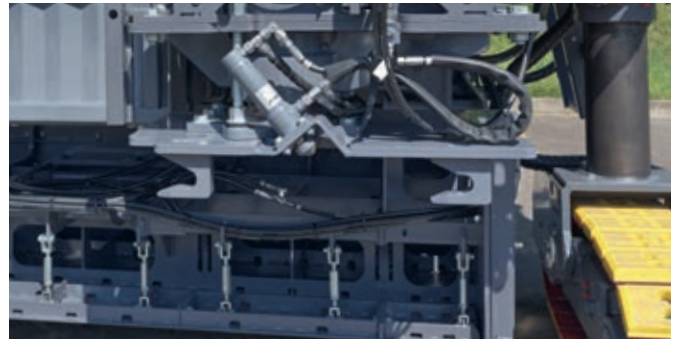

07 Trimmer

Trimmer for creating a datum surface before using offset paving molds. 2 ft (610 mm) m basic width, 8 ft (2.44 m) max. trim width. Hydraulic height adjustment by up to 16 in (400 mm) and hydraulic lateral shift of 52 in (1.3 m). Standard trimming depth up to approx. 4 in (100 mm).



08 AutoPilot 2.0 Machine Control

Control system for precise stringless control of the slipform paver to enable automated paving of, for example, concrete safety barriers or curb-gutter profiles.



The compact slipform paver can pave a wide range of monolithic concrete profiles such as, for example, curbs, curb-gutter profiles, rectangular profiles, concrete safety barriers up to a height of 52 in (1.3 m), drainage channels, and gutter profiles etc. In offset configuration, concrete surfaces up to a paving width of 7 ft (2.2 m) can also be realized in combination with a Trimmer with a width of up to 8 ft (2.4 m) - even slabs with a paving width of up to 10 ft (3.0 m) can be realized in Crosspave configuration without a Trimmer. The slipform paver is ideal for use on construction sites where a high degree of maneuverability, paving of tight radii, and maximum flexibility are required.



TECHNICAL DATA SP 33	Exhaust emission standard US EPA Tier 3		Exhaust emission standard US EPA Tier 4f	
Range of applications	Offset / Crosspave			
Concrete Feeding				
Belt conveyor	Length: 16 ft 1 in (4,900 mm), belt width: 2 ft (600 mm)			
Auger conveyor (Option)	Length: 15 ft 1 in (4,600 mm), auger diameter: 16 in (400 mm)			
Concrete Equipment for Offset Paving				
Configuration	Left or right			
Lateral mold adjustment	2-steps, up to 47 in (1,200 mm) (1 st step: 2 ft 4 in (700 mm), 2 nd step: 20 in (500 mm))			
Mold height adjustment (optional)	20 in (500 mm)			
Max. mold height	52 in (1,300 mm ¹⁾)			
Max. mold width	7 ft (2,200 mm ¹⁾)			
Concrete Equipment for Crosspave (Optional)				
Crosspave mold	7 ft 5 in - 10 ft (2,250 - 3,000 mm)			
Hopper wall	7 ft 5 in - 10 ft (2,250 - 3,000 mm)			
Spreading auger	7 ft 5 in - 10 ft (2,250 - 3,000 mm)			
Max. paving thickness ²⁾	12 in (300 mm) (hydr. side plate with 8 in (200 mm) lift with 4 in (100 mm) extension)			
Vibrators				
Connectors for hydraulic vibrators	6			
Connectors for hydraulic vibrators (Crosspave, optional)	8 (when used together with Trimmer: 6)			
Connectors for electric vibrators (optional)	6			
Trimmer (Optional)				
Standard width	2 ft (610 mm)			
Max. width	8 ft (2,440 mm ²⁾)			
Working depth ³⁾	0 - 4 in (0 - 100 mm)			
Cutting diameter	2 ft (610 mm)			
Hydraulic height adjustment	16 in (400 mm)			
Mechanical height adjustment	15 in (375 mm)			
Lateral Trimmer adjustment	52 in (1,300 mm ³⁾)			
Engine				
Engine manufacturer	Deutz	Deutz		
Type	TCD 2012 L04 2V AG3	TCD 4.1 L4		
Cooling system	Water	Water		
Number of cylinders	4	4		

TECHNICAL DATA SP 33	Exhaust emission standard US EPA Tier 3	Exhaust emission standard US EPA Tier 4f
Engine		
Rated power at 2,100 r.p.m.	92 kW / 123 HP / 125 PS	95 kW / 127 HP / 129 PS
Displacement	247 in ³ (4,040 cm ³)	247 in ³ (4,040 cm ³)
Fuel consumption under full load on-site mix	6.3 gal/h 2.2 gal/h (23.7 l/h 8.3 l/h)	6.6 gal/h 2.3 gal/h (25 l/h 8.8 l/h)
Engine sound power level according to EN 500-6 on operator's platform	≤ 103 dB(A) ≥ 80 dB(A)	≤ 99 dB(A) ≥ 80 dB(A)
Exhaust emission standard	US EPA Tier 3	US EPA Tier 4f
Electrical System		
Power supply	24 V	
Tank Capacities		
Fuel	55.5 gal (210 l)	
AdBlue® / DEF ⁴⁾	-	5.3 gal (20 l)
Hydraulic oil	58.1 gal (220 l)	
Water	55.5 gal (210 l)	42.3 gal (160 l)
Additional water tank	68.7 gal (260 l)	
Driving Performance		
Working speed	0 - 49 ft/min (0 - 15 m/min)	
Travel speed	0 - 115 ft/min (0 - 35 m/min)	
Track Units		
Number	3	
Arrangement	2 x front/1 x rear	
Dimensions (L x W x H)	Standard: 3 x 4 ft 5 in x 10 in x 22 in (1,340 x 260 x 550 mm) Optional: 2 x 4 ft 5 in x 10 in x 22 in (1,340 x 260 x 550 mm), 1 x 5 ft 4 in x 12 in x 23 in (1,620 x 300 x 580 mm)	
Machine Height Adjustment		
Hydraulic height adjustment	39 in (1,000 mm)	
Mechanical height adjustment	11 in (280 mm)	
Transport Dimensions (L x W x H)⁵⁾		
Base machine without concrete feeding system	18 ft 5 in x 8 ft 4 in x 9 ft 1 in (5,625 x 2,550 x 2,775 mm)	
Base machine with belt conveyor	25 ft 4 in x 8 ft 4 in x 9 ft 10 in (7,725 x 2,550 x 2,900 mm)	
Base machine with auger conveyor	23 ft 2 in x 8 ft 4 in x 9 ft 3 in (7,075 x 2,550 x 2,825 mm)	
Belt conveyor without chute	18 ft 2 in x 40 in x 2 ft 8 in (5,530 x 1,010 x 820 mm)	
Auger conveyor without chute	16 ft 9 in x 44 in x 42 in (5,100 x 1,130 x 1,060 mm)	
Trimmer	Min.: 4 ft 6 in x 2 ft 4 in x 2 ft 9 in (1,370 x 720 x 840 mm) Max.: 10 ft 6 in x 2 ft 4 in x 2 ft 9 in (3,200 x 720 x 840 mm)	
Machine Weights		
Operating weight, CE ⁶⁾	22,046 - 37,479 lbs (10,000 - 17,000 kg)	
Offset configuration, with belt conveyor, without Trimmer	27,778 lbs (12,600 kg)	
Offset configuration, with auger conveyor and Trimmer (36 in (915 mm))	33,069 lbs (15,000 kg)	
Crosspave configuration, with pre-fitting for Trimmer installation and grout box auger USA (10 ft (3 m))	31,967 lbs (14,500 kg)	

¹⁾ Other offset geometries and special applications on request

²⁾ Further mechanical shifting possible, depending on the working width

³⁾ Dependent on the respective application

⁴⁾ AdBlue® is a registered trademark of the German Association of the Automotive Industry (Verband der Automobilindustrie e. V.; VDA)

⁵⁾ All dimensions stated here are minimum values without an offset mold mounted on the paver

⁶⁾ Machine weight, half weight of all operating materials, machine operator (165 lbs (75 kg)), tools, no custom options; weights depend on the actual equipment installed and the working width

SIDE VIEW / TOP VIEW SP 33 OFFSET CONFIGURATION

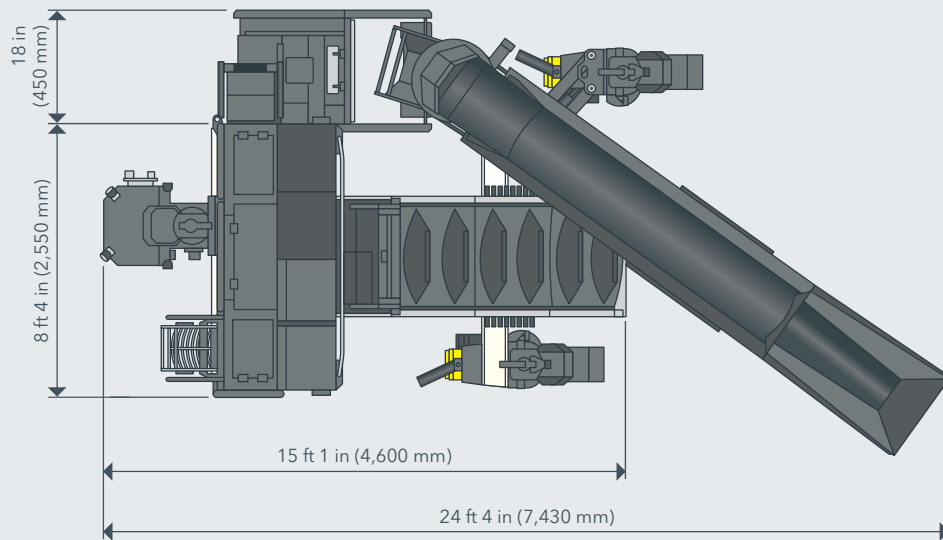
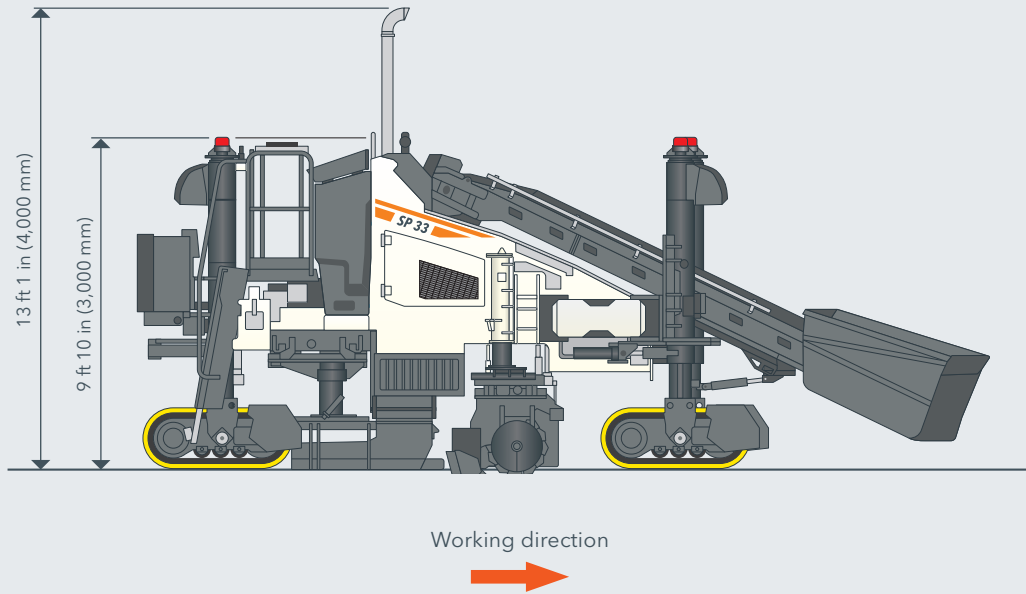

Variable pitch angle, belt

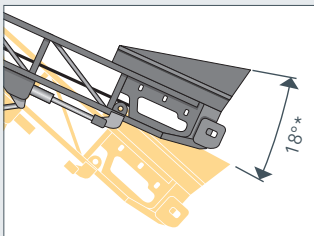

Longitudinal shift, belt conveyor

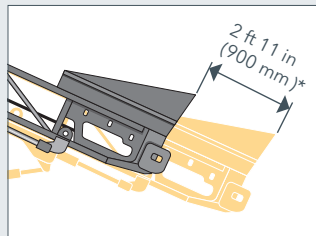

Transverse shift, belt conveyor

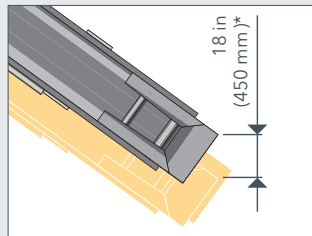

Slewing angle, belt conveyor

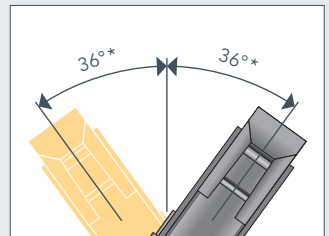

*Figures also apply to auger conveyor

TOP VIEW SP 33 OFFSET CONFIGURATION

Configuration of the crawler units and additional equipment

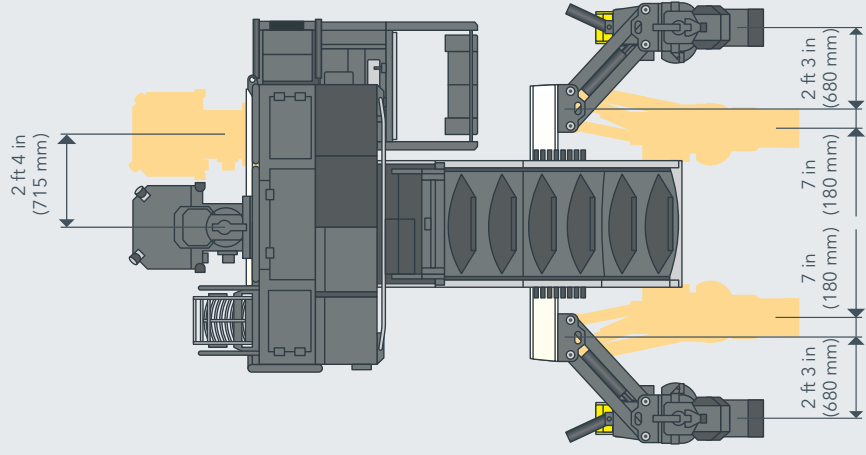

Working direction



Maneuvering radius, offset paving

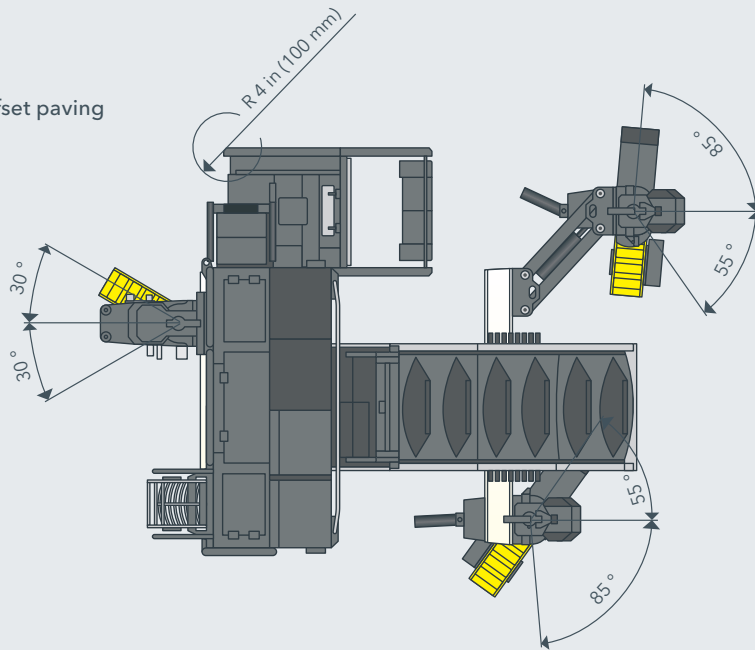

Usable paving radius

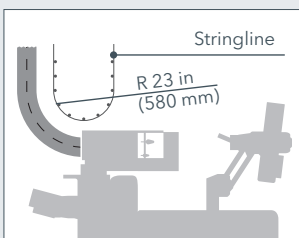

Paving radius along stringline, offset mold retracted

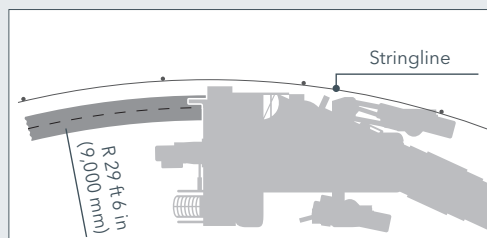

Paving radius along stringline, offset mold extended

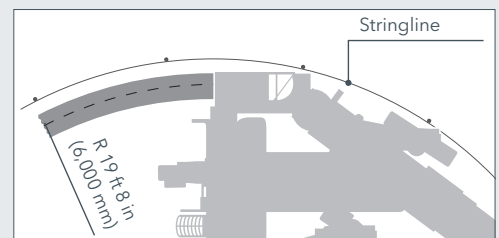

TOP VIEW SP 33 OFFSET CONFIGURATION

Configuration with
Trimmer

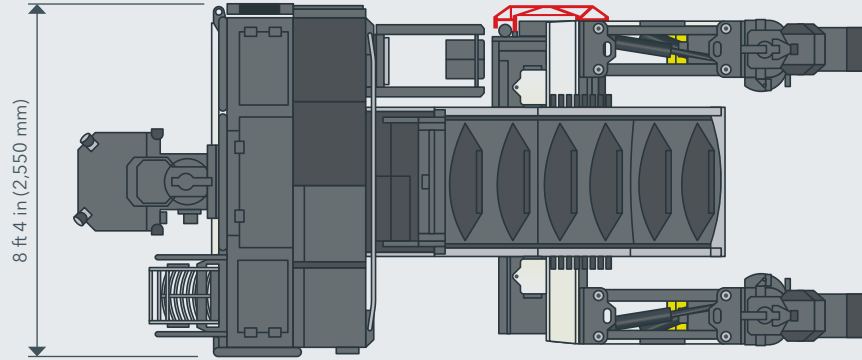

Working direction



Configuration with
Trimmer

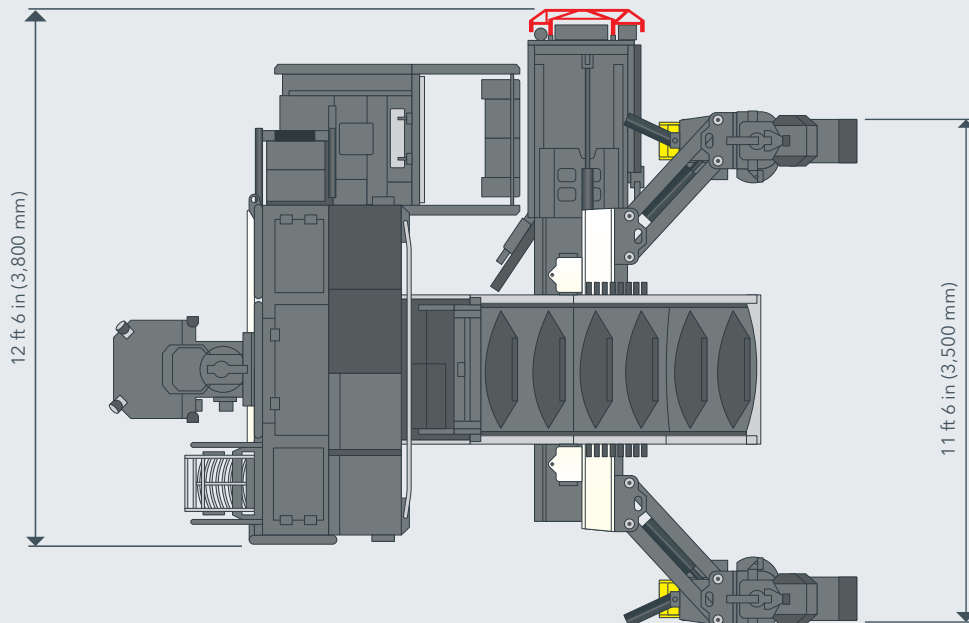

SIDE VIEW / TOP VIEW SP 33 CROSSPAVE CONFIGURATION

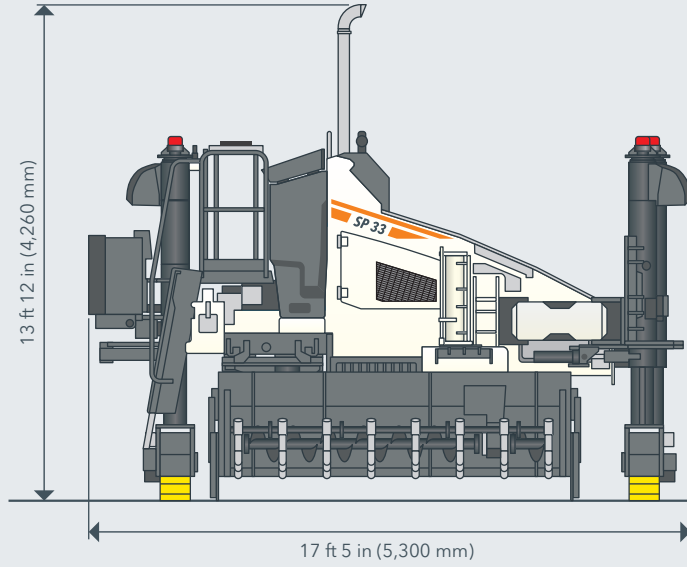

Working direction

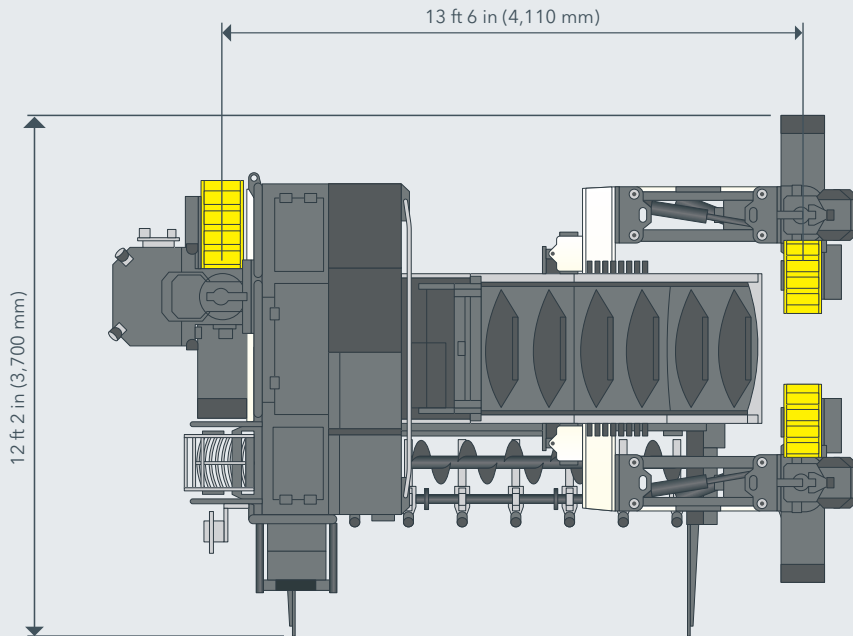

STANDARD FEATURES SP 33	Exhaust emission standard US EPA Tier 3	Exhaust emission standard US EPA Tier 4f
Base Machine		
> 58 gal (220 l) fuel tank	■	■
> 58 gal(220 l) hydraulic oil tank	■	■
> Electrical system (24V)	■	■
> A pressure and flow-rate controlled open circuit hydraulic pump for driving the track units	■	■
> A pressure and flow-rate controlled open circuit hydraulic pump for driving the hydraulic or electric vibrators	■	■
> A pressure-controlled open circuit hydraulic pump for all cylinder functions	■	■
> A proportionally controlled closed circuit hydraulic pump for driving the auger conveyor or belt conveyor	■	■
Main Frame and Height Adjustment		
> Robustly-constructed machine frame for accommodating two track units at the front and one track unit at the rear	■	■
Track Unit and Chassis Linkage		
> Three hydraulically driven 3-roller crawler units, 4 ft 5 in (1.34 m) long; optionally, a 5 ft 3 in (1.61 m) long 4-roller crawler unit can also be used at the rear (for even better traction and lower ground pressure); gear ratio 1:42; including towing cable attachment.	■	■
> Continuously adjustable paving speed from 0 to 49 ft/min (0 to 15 m/min)	■	■
> Continuously adjustable transport speed from 0 to 115 ft/min (0 to 35 m/min)	■	■
> Three hydraulic leveling cylinders with a stroke of 39 in (1.00 m) and integrated position measuring system	■	■
> The rear crawler unit can be moved along the rear suspension in order to select the most favorable position for the particular application It can also be moved hydraulically with a position measuring system as an additional option for even easier setup and display of the actual position of the crawler unit	■	■
> Configuration with one rigid and one slewing front crawler unit connection (parallelogram arm)	□	□
> Three crawler units (3 rollers) with triple-grouser track pads (steel)	□	□

STANDARD FEATURES SP 33	Exhaust emission standard US EPA Tier 3	Exhaust emission standard US EPA Tier 4f
Machine Control, Leveling, and Steering		
> CAN bus-based control and regulation system with touch-enabled 8" color display for intuitive machine operation, interactive machine display for set-up, transport, and concreting process, very clear set-up and diagnostics zone, choice of 11 different operating languages	■	■
> Proportional electro-hydraulic leveling and steering by means of an SPS system including two leveling sensors, two steering sensors, and one slope sensor	■	■
> Sensor mountings adjustable in height and range.	■	■
Vibrators		
> Hydraulic vibrator drive for up to 6 vibrators	□	□
> 2x straight vibrators D66, hydraulically driven	□	□
Concrete Feeding		
> Slider bed belt conveyor 16 ft 1 in x 2 ft (4.90 m x 0.60 m) with reversible hydraulic drive, hydraulically adjustable	□	□
> Steel chute	□	□
Concrete Equipment for Offset Paving		
> Offset molds can be mounted on the left or right side of the machine	■	■
> With the standard suspension, the mold can be telescoped outwards by 2 ft 4 in (0.70 m) at each side	■	■
> Mechanical standard mold suspension	□	□
> Offset paving mold up to 2 ft (0.60 m) wide, max. height 16 in (0.40 m)	□	□
Miscellaneous		
> Water tank with 42 gal (160 l) capacity and additional water tank with 77 gal (290 l) capacity	■	■
> Machine pre-fitted for installation of the John Deere Operations Center control unit	■	■
> European type certification, EuroTest mark, and CE conformity	■	■
> Pre-fitted electrics and hydraulics for concrete feeding inside the machine	■	■
> Standard paint finish RAL 9001 (cream)	□	□
> John Deere Operations Center: Digital solutions for process, machine, and service optimization	□	□
> High-performance lighting system with 4 LED working lights, 24V	□	□

- = Standard equipment
- = Standard equipment, can be replaced with optional equipment if desired
- = Optional equipment

OPTIONAL EQUIPMENT SP 33	Exhaust emission standard US EPA Tier 3	Exhaust emission standard US EPA Tier 4f
Track Unit and Chassis Linkage		
> Two slewing front track units (parallelogram arms)	<input type="checkbox"/>	<input type="checkbox"/>
> Three crawler units (3 rollers at the front, 4 rollers at the rear) with triple-grouser track pads (steel)	<input type="checkbox"/>	<input type="checkbox"/>
> Three crawler units (3 rollers) with polyurethane track pads	<input type="checkbox"/>	<input type="checkbox"/>
> Three crawler units (3 rollers at the front, 4 rollers at the rear) with polyurethane track pads	<input type="checkbox"/>	<input type="checkbox"/>
Machine Control, Leveling, and Steering		
> Hydraulic components, rear 90°-steering	<input type="checkbox"/>	<input type="checkbox"/>
> Two slab tracers	<input type="checkbox"/>	<input type="checkbox"/>
> Third height and steering sensor for tight cornering	<input type="checkbox"/>	<input type="checkbox"/>
> Pre-fitted for installation of AutoPilot or a third-party 3D system	<input type="checkbox"/>	<input type="checkbox"/>
Vibrators		
> Electric vibrator drive with 10 kVA generator for up to 6 vibrators	<input type="checkbox"/>	<input type="checkbox"/>
> Hydraulic vibrator drive for up to 8 vibrators	<input type="checkbox"/>	<input type="checkbox"/>
> 2x bent vibrators D66, hydraulic	<input type="checkbox"/>	<input type="checkbox"/>
> 2x straight vibrators D66, electric	<input type="checkbox"/>	<input type="checkbox"/>
> 2x bent vibrators D66, electric	<input type="checkbox"/>	<input type="checkbox"/>
> Straight vibrator D66, hydraulic	<input type="checkbox"/>	<input type="checkbox"/>
> Bent vibrator D66, hydraulic	<input type="checkbox"/>	<input type="checkbox"/>
> Straight vibrator D66, electric	<input type="checkbox"/>	<input type="checkbox"/>
> Bent vibrator D66, electric	<input type="checkbox"/>	<input type="checkbox"/>
Concrete Equipment for Slab Paving		
> Crosspave mold, metric - base width 7 ft 5 in (2.25 m)	<input type="checkbox"/>	<input type="checkbox"/>
> Mold suspension without additional height adjustment	<input type="checkbox"/>	<input type="checkbox"/>
> Mold suspension with additional height adjustment	<input type="checkbox"/>	<input type="checkbox"/>
> Crosspave mold - 10 in (0.25 m) extension element	<input type="checkbox"/>	<input type="checkbox"/>
> Crosspave mold - 20 in (0.50 m) extension element	<input type="checkbox"/>	<input type="checkbox"/>
> One-piece grout box auger - base width 7 ft 5 in (2.25 m)	<input type="checkbox"/>	<input type="checkbox"/>
> Grout box auger - 10 in (0.25 m) extension element	<input type="checkbox"/>	<input type="checkbox"/>
> Grout box auger - 20 in (0.50 m) extension element	<input type="checkbox"/>	<input type="checkbox"/>
Concrete Feeding		
> 15 ft 1 in x 16 in (4.60 m x 0.40 m) auger conveyor with reversible hydraulic drive, hydraulically adjustable	<input type="checkbox"/>	<input type="checkbox"/>
> Steel-rubber chute for feeding concrete into the offset mold	<input type="checkbox"/>	<input type="checkbox"/>
Concrete Equipment for Offset Paving		
> Hydraulically shiftable standard mold suspension	<input type="checkbox"/>	<input type="checkbox"/>
> Fully hydraulic premium mold suspension	<input type="checkbox"/>	<input type="checkbox"/>
> Height adapter for split offset molds	<input type="checkbox"/>	<input type="checkbox"/>
> Height-adjustable suspension with 20 in (0.50 m) lift for split offset mold	<input type="checkbox"/>	<input type="checkbox"/>
> Hydraulic quick-change system for offset molds (for one-part mold)	<input type="checkbox"/>	<input type="checkbox"/>
> Additional adapter plate for quick-change system	<input type="checkbox"/>	<input type="checkbox"/>
> Hydraulic quick-change system for offset mold (two-part mold)	<input type="checkbox"/>	<input type="checkbox"/>
> Height adapter for split offset molds for use with Trimmer	<input type="checkbox"/>	<input type="checkbox"/>
> Split offset mold up to 24 in (0.60 m) wide, max. height 16 in (0.40 m)	<input type="checkbox"/>	<input type="checkbox"/>
> Offset mold from 24 in (0.60 m) to 47 in (1.20 m) wide, max. height 16 in (0.40 m)	<input type="checkbox"/>	<input type="checkbox"/>
> Offset mold from 47 in (1.20 m) to 5 ft 11 in (1.80 m) wide, max. height 16 in (0.40 m)	<input type="checkbox"/>	<input type="checkbox"/>
> Offset mold up to 35 in (0.90 m high), max. base width 24 in (0.60 m), including hopper	<input type="checkbox"/>	<input type="checkbox"/>

OPTIONAL EQUIPMENT SP 33	Exhaust emission standard US EPA Tier 3	Exhaust emission standard US EPA Tier 4f
Concrete Equipment for Offset Paving		
> Offset mold up to 52 in (1.30 m) high, max. base width 24 in (0.60 m), including hopper	<input type="checkbox"/>	<input type="checkbox"/>
> Split offset mold from 24 to 47 in (0.60 m to 1.20 m) wide, max. height 16 in (0.40 m)	<input type="checkbox"/>	<input type="checkbox"/>
> Split combined offset mold up to 2 ft 6 in (0.75 m) wide and max. height of 16 in (0.40 m)	<input type="checkbox"/>	<input type="checkbox"/>
> Split combined offset mold up to 43 in (1.10 m) wide and max. height of 16 in (0.40 m)	<input type="checkbox"/>	<input type="checkbox"/>
> Offset paving mold up to 24 in (0.60 m) wide, max. height 16 in (0.40 m)	<input type="checkbox"/>	<input type="checkbox"/>
> Bottom part for split offset paving mold (AV) up to 24 in (0.60 m) wide (max. height 16 in (0.40 m))	<input type="checkbox"/>	<input type="checkbox"/>
> Bottom part for split offset paving mold (AV) from 24 to 47 in (0.60 m to 1.20 m) wide (max. height 16 in (0.40 m))	<input type="checkbox"/>	<input type="checkbox"/>
> Profile insert for split combined offset mold up to 30 in (0.75 m) in width	<input type="checkbox"/>	<input type="checkbox"/>
> Profile insert for split combined offset mold up to 43 in (1.10 m) in width	<input type="checkbox"/>	<input type="checkbox"/>
> Set of hydraulic components for adjusting the side plates of an EV offset mold	<input type="checkbox"/>	<input type="checkbox"/>
> Set of hydraulic components for adjusting the side plate of an AV offset mold	<input type="checkbox"/>	<input type="checkbox"/>
Offset Trimmer		
> Trimmer, basic width 24 in (0.61 m), for mounting on the left	<input type="checkbox"/>	<input type="checkbox"/>
> Trimmer, basic width 24 in (0.61 m), for mounting on the right	<input type="checkbox"/>	<input type="checkbox"/>
> Pre-fitted electrics and hydraulics for Trimmer	<input type="checkbox"/>	<input type="checkbox"/>
> 12 in (0.30 m) Trimmer extension for mounting on the left	<input type="checkbox"/>	<input type="checkbox"/>
> 18 in (0.45 m) Trimmer extension for mounting on the left	<input type="checkbox"/>	<input type="checkbox"/>
> 24 in (0.61 m) Trimmer extension for mounting on the left	<input type="checkbox"/>	<input type="checkbox"/>
> 12 in (0.30 m) Trimmer extension for mounting on the right	<input type="checkbox"/>	<input type="checkbox"/>
> 18 in (0.45 m) Trimmer extension for mounting on the right	<input type="checkbox"/>	<input type="checkbox"/>
> 24 in (0.61 m) Trimmer extension for mounting on the right	<input type="checkbox"/>	<input type="checkbox"/>
Operator's Platform		
> Weather canopy for operator's platform	<input type="checkbox"/>	<input type="checkbox"/>
Miscellaneous		
> One special paint color (RAL)	<input type="checkbox"/>	<input type="checkbox"/>
> Custom painting in two colors (RAL)	<input type="checkbox"/>	<input type="checkbox"/>
> Version without John Deere Operations Center	<input type="checkbox"/>	<input type="checkbox"/>
> High-performance lighting system with 11 LED working lights, 24V	<input type="checkbox"/>	<input type="checkbox"/>
> High-pressure cleaner	<input type="checkbox"/>	<input type="checkbox"/>
> Additional water pump, 24V	<input type="checkbox"/>	<input type="checkbox"/>
> Favorites panel (up to 5)	<input type="checkbox"/>	<input type="checkbox"/>
> Additional control panel housing with storage option on the operator's platform	<input type="checkbox"/>	<input type="checkbox"/>
> Additional walkway extension	<input type="checkbox"/>	<input type="checkbox"/>
> LED floodlight, 24V	<input type="checkbox"/>	<input type="checkbox"/>
> Stringline tensioning system, complete with 3,281 ft (1,000 m) steel wire rope	<input type="checkbox"/>	<input type="checkbox"/>
> Additional tensioning winch for the stringline tensioning system	<input type="checkbox"/>	<input type="checkbox"/>
> Stringline tensioning system, complete with 4 x 984 ft (300 m) nylon cord	<input type="checkbox"/>	<input type="checkbox"/>
> Radius kit, fiberglass rod as stringline alternative for paving in corners with different radii	<input type="checkbox"/>	<input type="checkbox"/>

- = Standard equipment
- = Standard equipment, can be replaced with optional equipment if desired
- = Optional equipment

**WIRTGEN AMERICA Inc.**

6030 Dana Way
Antioch, TN 37013, USA

P: (615) 501-0600
F: (615) 501-0691

 www.wirtgen-group.com/america



Please scan the code for further information.