

Technical information

SUPER 1900-3 Li



Tracked paver SUPER 1900-3 Li
Highway Class

TECHNICAL HIGHLIGHTS

- > Maximum pave width 11 m
- > Maximum laydown rate 900 t/h
- > Transport width 3 m
- > Engine output: 145 kW at 2,000 rpm

SUPER 1900-3 Li - powerful, efficient and economical

The tracked SUPER 1900-3 Li paver has been designed especially for the Chinese market. As model of the "Dash 3" paver generation from VÖGELE the machine unites ergonomic operating comfort as well as high performance with minimum consumption.

Featuring the latest in paver technology, this cutting-edge paver meets even most demanding challenges.



TECHNICAL DATA	SUPER 1900-3 Li
Power unit	
Engine	
> Version	liquid-cooled 6-cylinder diesel engine
> Manufacturer	Cummins
> Type	B6.7
Output	
> Nominal	145 kW at 2,000 rpm
> ECO mode	140 kW at 1,700 rpm
Emissions information	
> Exhaust emissions standards	NR4
Fuel tank	380 litres
Undercarriage	
Crawler tracks	
> Version	provided with rubber pads
> Ground contact	3,060 x 305 mm
> Track tension adjuster	spring assembly
> Lubrication of track rollers	lifetime
Traction drive	separate hydraulic drive and electronic control provided for each crawler track
Speeds	
> Paving	up to 25 m/min., infinitely variable
> Transport	up to 4.5 km/h, infinitely variable
Material hopper	
Hopper capacity	15 t
Width	3,265 mm
Feed height	550 mm (bottom of material hopper)
> Hopper Front, manual	480 mm
> Hopper Front, hydraulic	570 mm
Push-rollers	
> Standard	oscillating
Position	oscillating, can be displaced forwards by 75 mm or 150 mm
Conveyors and augers	
Conveyors	
> Version	2, with replaceable feeder bars, conveyor movement reversible for a short time
> Drive	separate hydraulic drive provided for each conveyor
> Speed	up to 37 m/min., infinitely variable (manual or automatic)

Conveyors and augers

Augers			
> Version	2, with exchangeable auger blades, auger rotation reversible		
> Diameter	480 mm (AB 600, SB 300) 400 mm (SB 300 HD)		
> Drive	separate hydraulic drive provided for each auger		
> Speed	max. 95 rpm, infinitely variable (manual or automatic)		
> Height	infinitely variable by 15 cm, hydraulic		
Lubrication	centralized lubrication system with electrically driven grease pump		
Screed options	AB 600	SB 300	SB 300 HD
Basic width	3 m to 6 m	3 m	3 m
Maximum width	10 m	11 m	9 m
Compacting systems	TV	TV	T
Layer thickness	up to 40 cm (SB 300)		
Screed heating			
> Version	electric by heating rods*		
> Power supply	three-phase AC generator		

Dimensions (transport) and weights

Length	
> Version	tractor unit and screed
> AB 600	6.96 m
> SB 300	7.06 m
> SB 300 HD	6.86 m
Weights	
> Version	tractor unit and screed
> AB 600	pave widths up to 6 m: 22,150 kg / pave widths up to 10 m: 25,800 kg

Key: AB = Extending Screed, SB = Fixed-Width Screed, HD = Heavy-Duty, T = with tamper, TV = with tamper and vibrators, * = not for SB 300 HD

SIDE AND FRONT VIEW

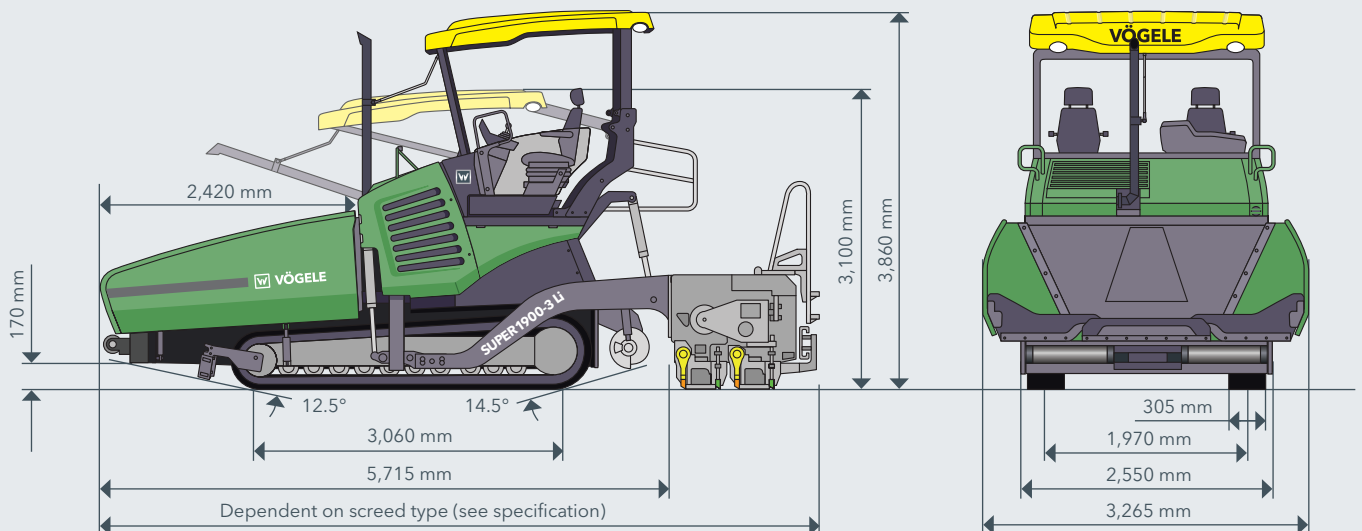

THE HIGHLIGHTS OF THE SUPER 1900-3 Li

- > Tracked Highway Class paver with a large range of applications and pave widths up to 11 m
- > Powerful and economical drive concept, even when operating at full load in any climate zone
- > "VÖGELE EcoPlus" low-emissions package for a low carbon footprint significantly reduces fuel consumption and noise levels
- > The powerful, oil-cooled generator is directly driven by the splitter gearbox and therefore maintenance-free
- > ErgoPlus 3 operating system with numerous convenient and automatic functions
- > Extra long material hopper and chassis

EQUIPMENT

> Electronic engine management with ECO mode and variable-speed fan drive	■
> ErgoPlus 3 operating concept with numerous additional ergonomic and functional advantages	■
> Modern hardtop, made of a glass fibre-reinforced polymer material	■
> Operator's seat, luxury, 2 pieces	■
> 6 working lights, LED	■
> Limiting plates for auger tunnel, hinged	□
> Automated Grade and Slope Control Niveltronic Plus	□
> Various sensor types are available for the Niveltronic Plus	□
> Washdown system with tank and hose reel	□

This list is just an extract of the scope of supply.

■ Standard feature □ Option

JOSEPH VÖGELE AG

Joseph-Vögele-Str. 1
67075 Ludwigshafen
Germany

T: +49 621 8105-0
F: +49 621 8105-461
M: marketing@voegele.info

➤ www.voegele.info

