

Technical information

# SUPER 1700-3i



## Tracked paver SUPER 1700-3i

Universal Class

### TECHNICAL HIGHLIGHTS

- > Maximum paving width 19 ft. 6 in. (5.95 m)
- > Maximum laydown rate 770 tons/h (700 tonnes/h)
- > Transport width 8 ft. 6 in. (2.59 m)
- > Engine output: 173 hp (129 kW) at 2,000 rpm

### SUPER 1700-3i - the versatile asphalt paver

The VÖGELE SUPER 1700-3i is a cutting-edge paver in the 8-foot class. Conceived especially for the North American and Australian markets, the tracked machine handles a wide variety of paving jobs. Thanks to its compact design, the SUPER 1700-3i is the ideal partner for inner-city applications.

The innovative and easy-to-learn ErgoPlus 3 operating system is every machine operator's dream, providing ergonomic working conditions tailored to real-life use. The screed operating consoles have been completely redesigned, making operation of this new "Dash 3" machine even easier for the entire paving crew.



## TECHNICAL DATA

### Power unit

<b>Engine</b>	
> Version	4-cylinder diesel engine, liquid-cooled
> Manufacturer	Cummins
> Type	QSB4.5 - C173
<b>Output</b>	
> Nominal	173 hp (129 kW) at 2,000 rpm (according to DIN)
> ECO mode	160 hp (119 kW) at 1,700 rpm
<b>Emissions information</b>	
> Exhaust emissions standards	EU Stage 4, US EPA Tier 4f
> Exhaust gas after-treatment	DOC, SCR
<b>Fuel tank</b>	58 gallons (220 liters)

### Undercarriage

<b>Crawler tracks</b>	
> Version	continuous rubber band
> Ground contact	8 ft. 6 in. x 1 ft. 2 in. (2,594 mm x 355 mm)
> Track tension adjuster	lifetime grease lubricated
> Lubrication of track rollers	lifetime
<b>Traction drive</b>	separate hydraulic drive and electronic control provided for each crawler track
<b>Speeds</b>	
> Paving	up to 250 fpm (76 m/min.), infinitely variable
> Travel	up to 7.5 mph (12 km/h), infinitely variable

### Material hopper

<b>Hopper capacity</b>	14.3 tons (13 tonnes), including conveyor tunnel
<b>Width</b>	10 ft. 9 in. (3,265 mm)
<b>Feed height</b>	24 in. (615 mm)
<b>Push-rollers</b>	
> Standard	oscillating
> Position	can be displaced forwards by 3 in. (75 mm) or 6 in. (150 mm)
> Option	truck hitch

Conveyors and augers	
<b>Conveyors</b>	
> Version	2, with replaceable feeder bars, conveyor movement reversible for a short time
> Drive	separate hydraulic drive provided for each conveyor
> Speed	up to 130 fpm (40 m/min.), infinitely variable (manual or automatic)
<b>Augers</b>	
> Version	2, with exchangeable auger blades, auger rotation reversible
> Diameter	16 in. (400 mm)
> Drive	separate hydraulic drive provided for each auger
> Speed	up to 120 rpm, infinitely variable (manual or automatic)
> Height	infinitely variable by 6 in. (15 cm), hydraulic
<b>Lubrication</b>	automatic centralized lubrication system with electrically driven grease pump
<b>Screed</b>	<b>VF 500</b>
<b>Basic width</b>	8 ft. to 15 ft. 6 in. (2.45 m to 4.75 m)
<b>Maximum width</b>	19 ft. 6 in. (5.95 m)
<b>Compacting systems</b>	V
<b>Layer thickness</b>	up to 12 in. (30 cm)
<b>Screed heating</b>	
> Version	electric by heating rods
> Power supply	three-phase AC generator
Dimensions (transport) and weights	
<b>Length</b>	
> Version	tractor unit and screed
> VF 500 V	18 ft. 5 in. (5.6 m)
<b>Weights</b>	
> Version	tractor, hardtop and screed
> VF 500 V	40,345 lbs. (18,300 kg)

Key: DOC = Diesel Oxidation Catalyst, SCR = Selective Catalytic Reduction, VF = Screed with Front-Mounted Extensions, V= with vibration

SIDE AND FRONT VIEW

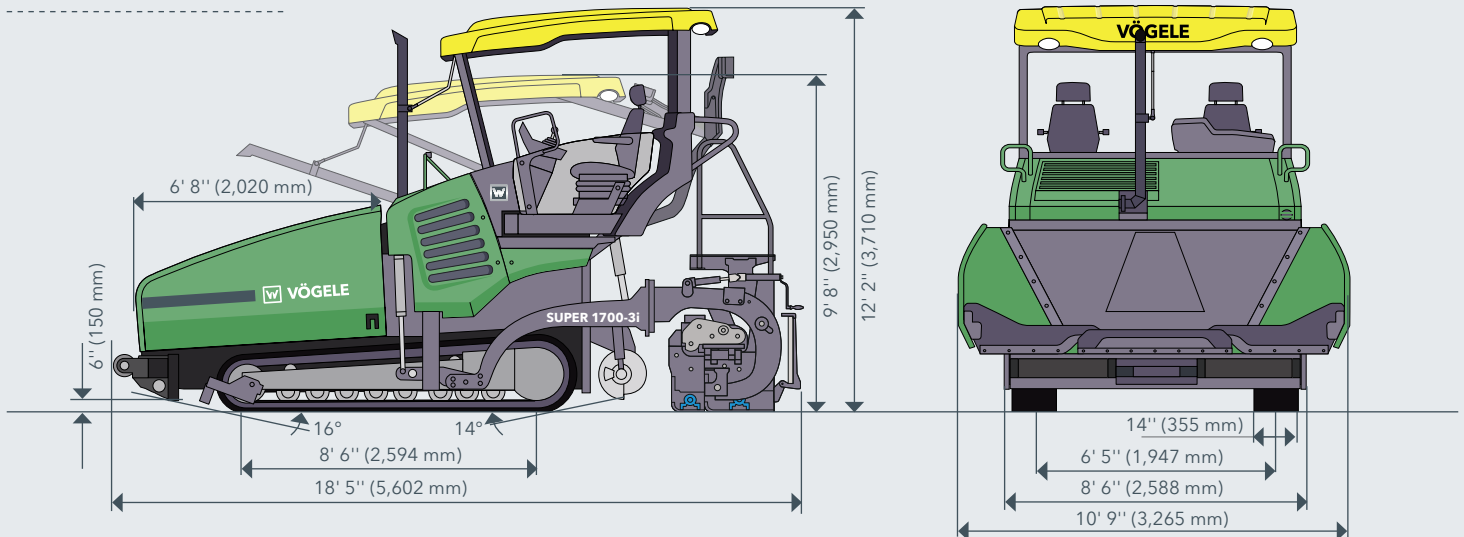

## THE HIGHLIGHTS OF THE SUPER 1700-3i

- > Tracked Universal Class paver with a large range of applications and pave widths up to 19 ft. 6 in. (5.95 m)
- > Powerful engine complying with US EPA standard Tier 4f
- > The VÖGELE EcoPlus low-emissions package significantly reduces fuel consumption and noise levels
- > Optimum feeding with mix thanks to the large material hopper holding 14.3 tons (13 tonnes)
- > ErgoPlus 3 with a number of additional ergonomic and functional advantages
- > Fully-integrated Niveltronic Plus, the System for Automatic Grade and Slope Control
- > High paving speeds up to 250 fpm (76 m/min)

## FEATURES

> Large receiving hopper holding 14.3 tons (13 tonnes)	■
> Hydraulic hopper front	■
> Truck hitch	□
> Simple, ergonomic ErgoPlus 3 operating concept	■
> Working lights, LED	■
> Powerful oil-cooled generator	■
> VÖGELE EcoPlus low-emissions package	■
> LED light balloon for use at night	□
> NEMA power outlet, 120 V	□
> Sonic sensor to control augers	■
> Power Tunnel - hydraulically adjusted limiting plates for auger tunnel	■
> Niveltronic Plus System for Automated Grade and Slope Control	■
> Various sensor types are available for the Niveltronic Plus	□
> VÖGELE RoadScan comprehensive asphalt temperature measuring system	□
> WITOS Paving FleetView Telematics System	■
> Ventilation System	■

This list is just an extract of the scope of supply.  
Standard features and options may differ by sales region.

■ Standard feature    □ Option

### Wirtgen America, Inc.

6030 Dana Way  
Antioch, TN 37013  
USA

T: 615 501-0600  
F: 615 501-0691

➤ [www.wirtgen-group.com/america](http://www.wirtgen-group.com/america)

